



Haus A

Zuhause mit Mehrwert

Grosszügiges Einfamilienhaus mit vermietbarer Einliegerwohnung



Haus A



1:500



HAUS A CHF 1'578'000.00

EFH inkl. Einlieger-Whg

Wohnfläche Total (HNF)	144.05m ²
Keller + Vorplatz (NNF)	25m ²
Terrasse	34.80m ²
Sitzplatz	6.60m ²
Balkon	3.90m ²

Grundstücksfläche	1077m ²
Landanteil	CHF 248'000.00

ALLGEMEIN

Parkplätze

Parkplatz Gross	je 40'000.00 CHF
Parkplatz Standard	je 35'000.00 CHF

Keller 01 35'000.00 CHF

Fläche 14.05m²

Keller 02 35'000.00 CHF

Fläche 14.55m²

Keller 03 40'000.00 CHF

Fläche 16.60m²

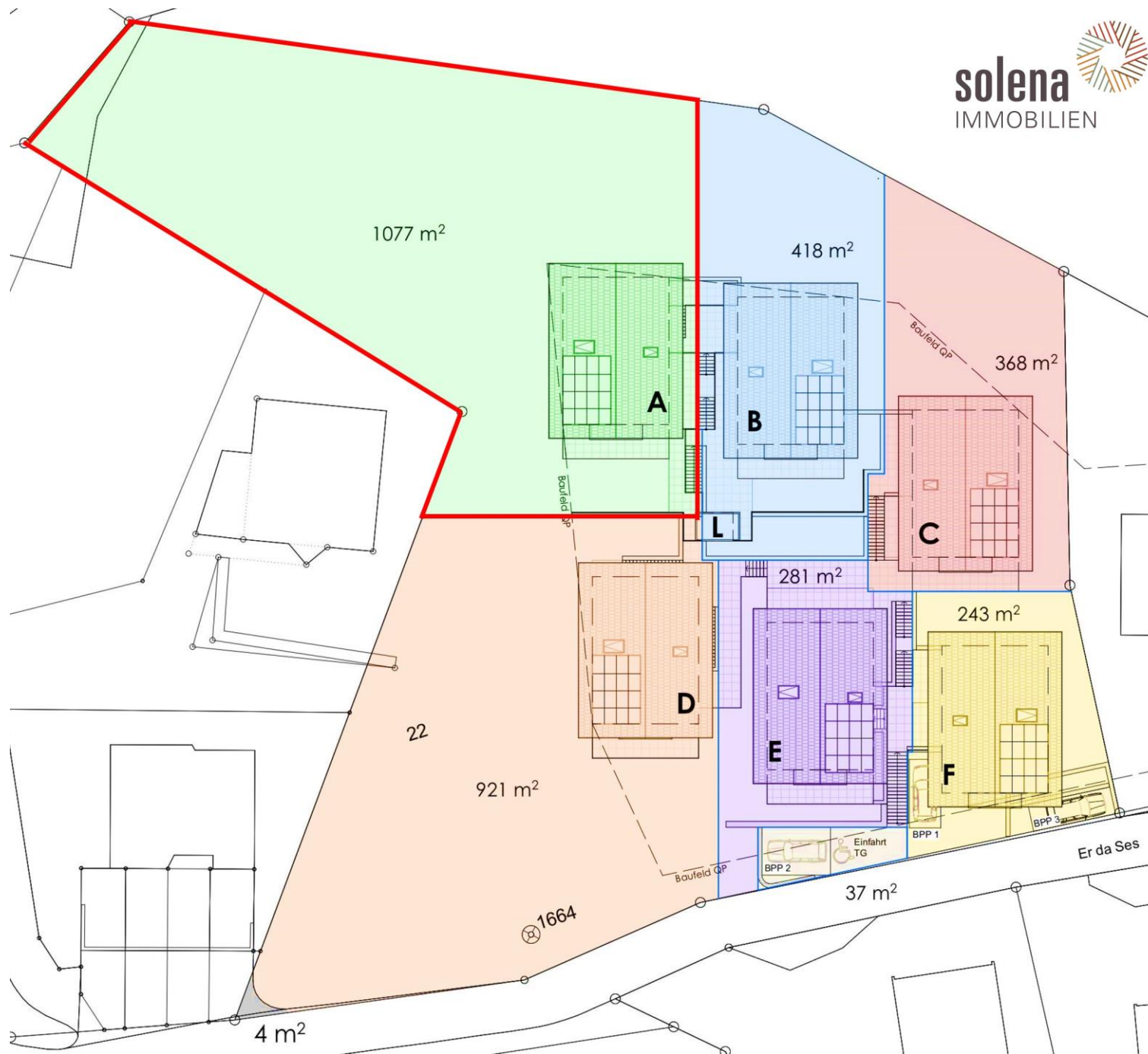

Garage & Zwischengeschoss

2 Garagenplätze

Zu erwerbende Kellerabteile

Lift ins Erdgeschoss

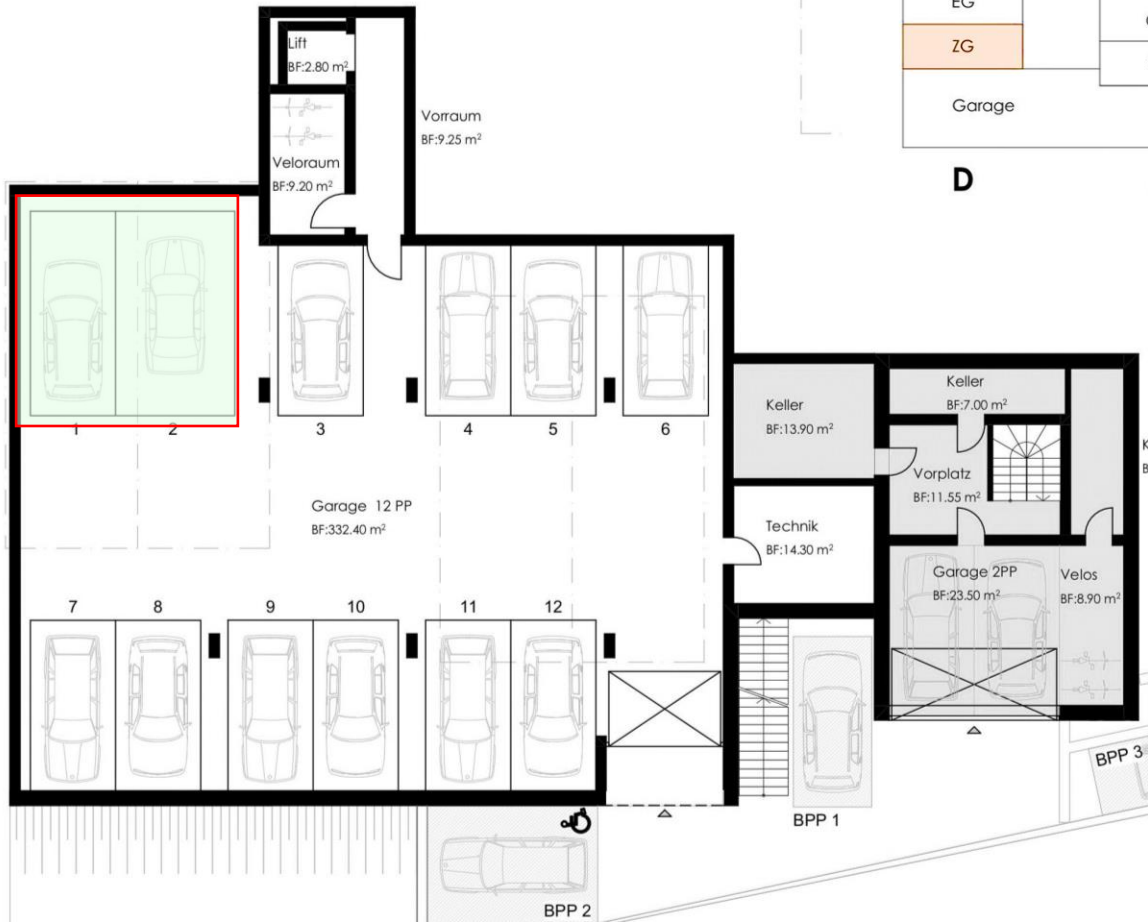

GRÖSSE

Vorplatz (NNF)	7.30m ²
Keller Haus D (NNF)	17.70m ²
Keller 02	14.05m ²
Keller 03	14.55m ²
Keller 04	16.60m ²

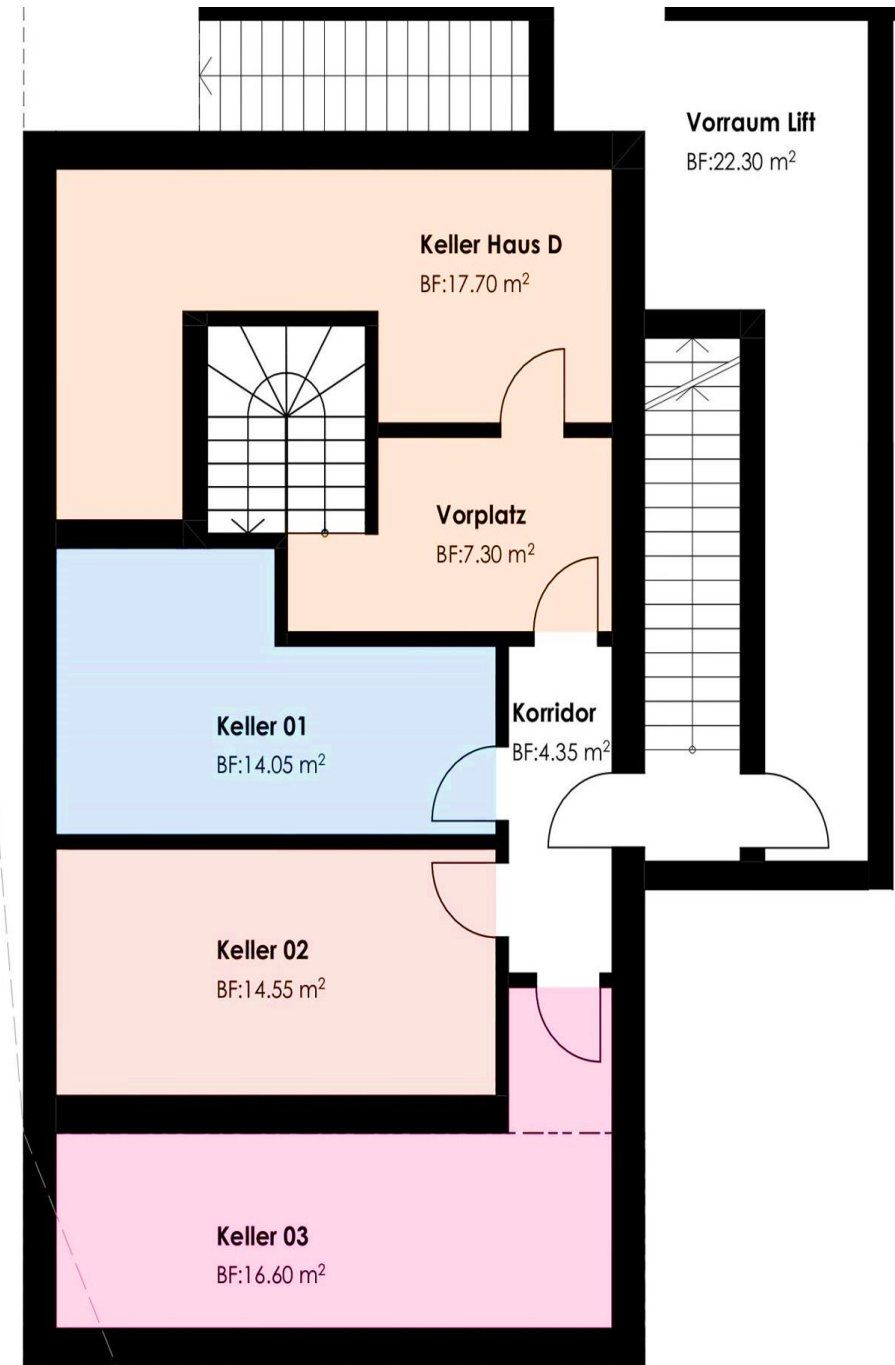
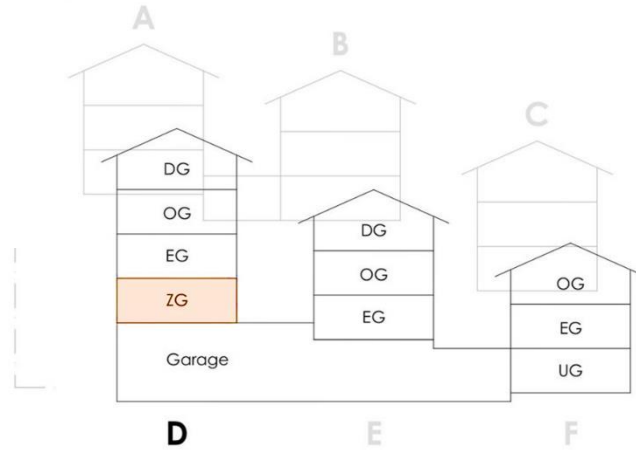

Vorteile einer Einliegerwohnung

Finanzierungsvorteil

Zusätzliches Einkommen

Viele Nutzungsmöglichkeiten

Wertsteigerung Immobilie

HAUS A ERDGESCHOSS

GRÖSSE

Wohnfläche Erdgeschoss (HNF)	28.25m ²
Vorplatz (NNF)	7.30m ²
Keller (NNF)	17.70m ²
Terrasse	16.05m ²

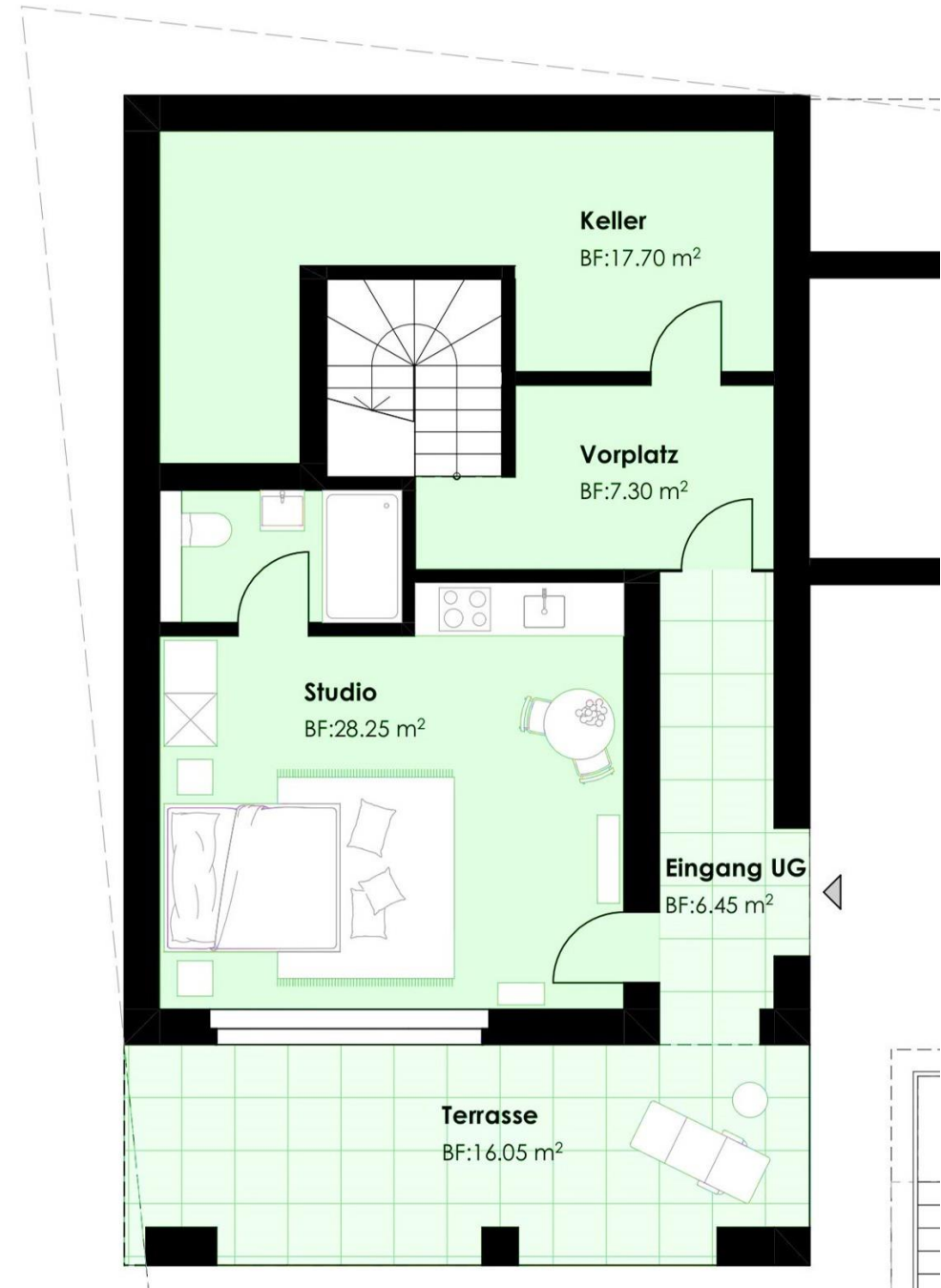
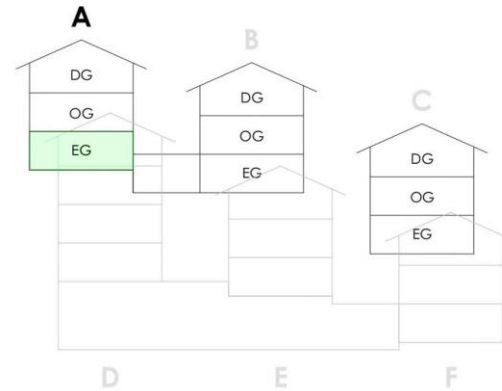

Stylisches Wohnen

Einladende Atmosphäre

Lichtdurchflutet

Hochwertige Materialien

Offener Grundriss

Moderne Kochinsel

HAUS A OBERGESCHOSS

GRÖSSE

Wohnfläche Obergeschoss (HNF)	55.45m ²
Sitzplatz gedeckt	6.60m ²
Terrasse	18.75m ²

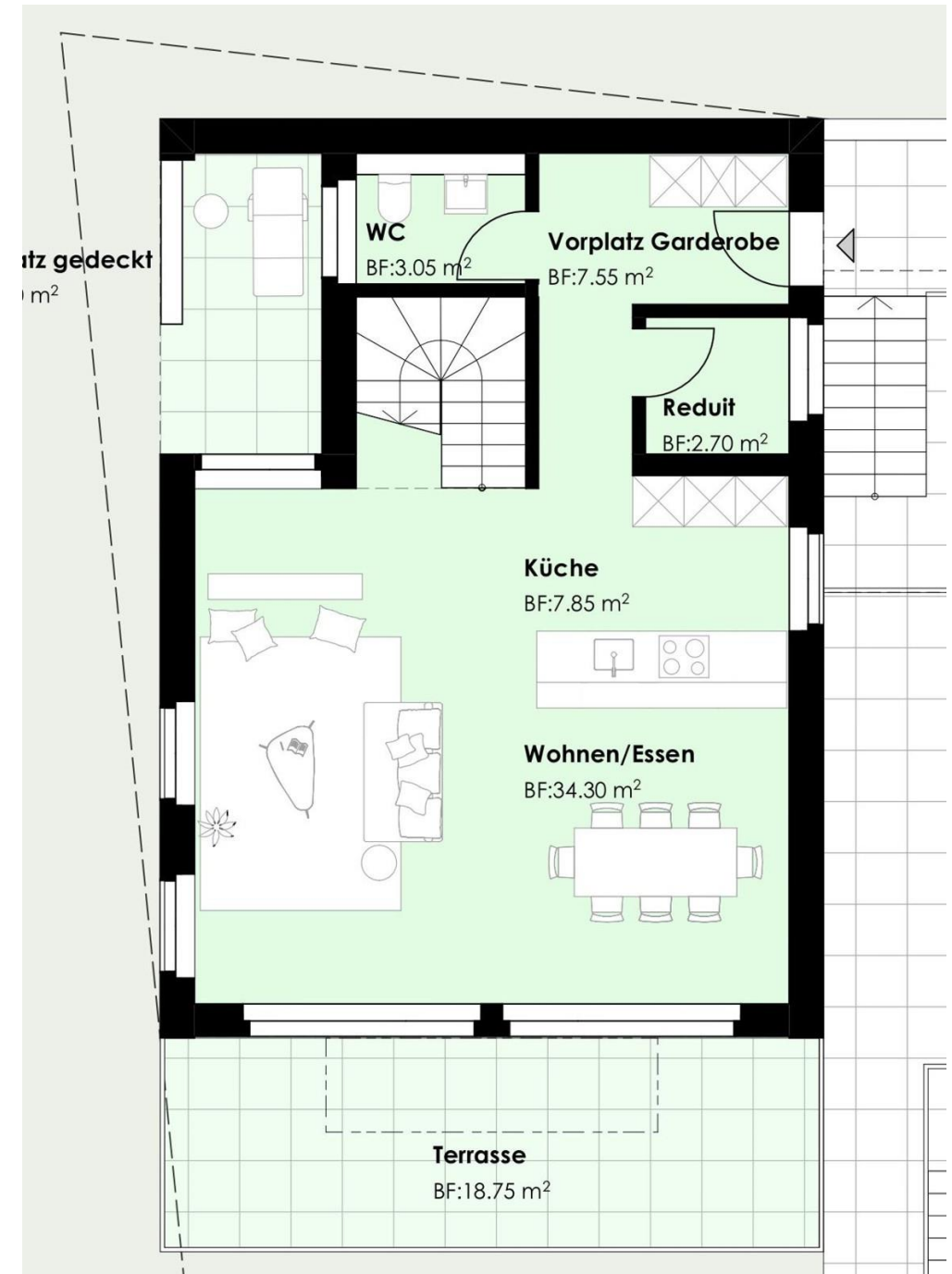
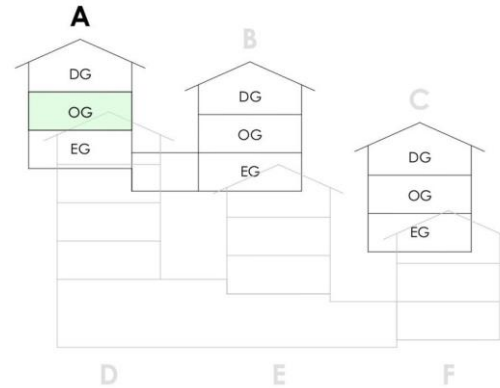

Dachgeschoss

Drei grosszügige Zimmer

Herrliches Badezimmer

Gäste-WC / Dusche

Südbalkon – Grandiose Aussicht

Gemütliche Holzdachuntersicht

HAUS A DACHGESCHOSS

GRÖSSE

Wohnfläche Dachgeschoss (HNF) 60.35m²
Balkon 3.90m²

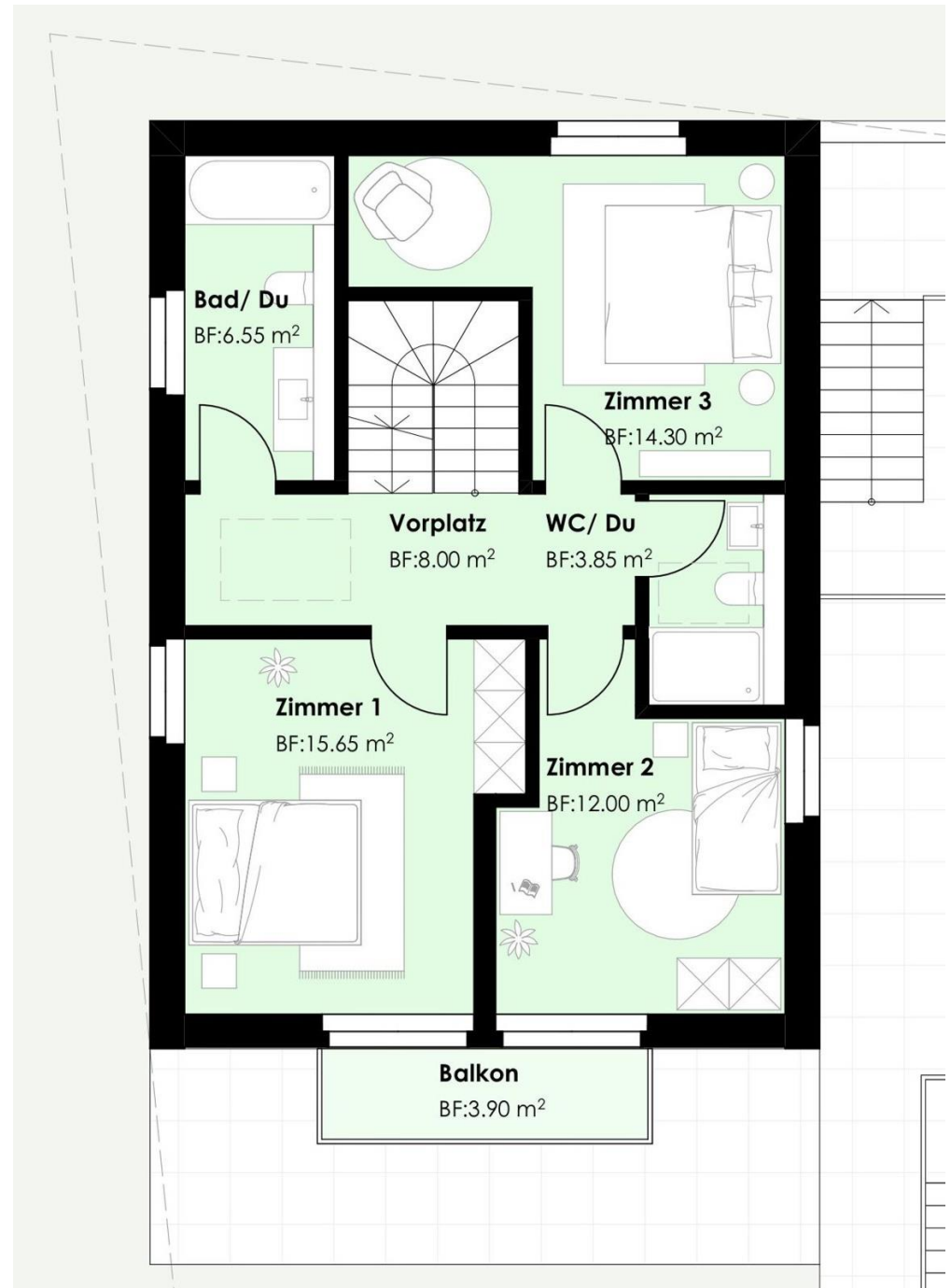
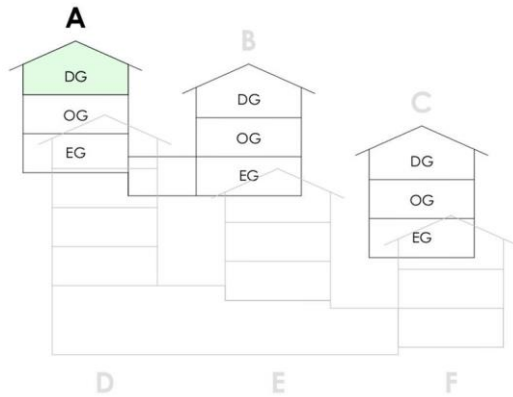





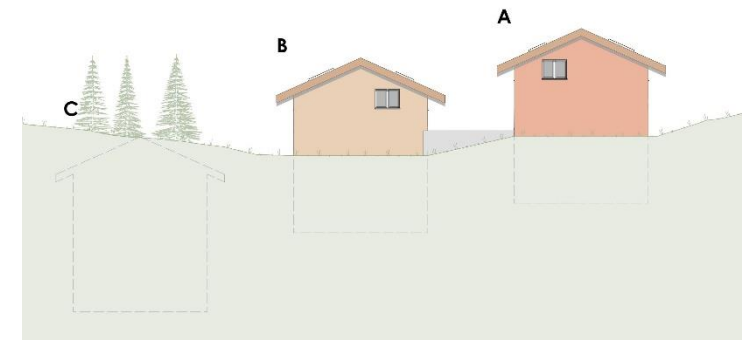
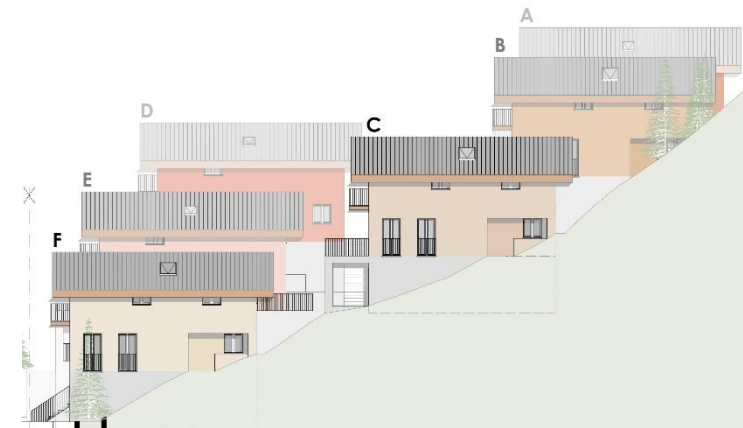
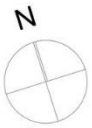

Leben in Bergün – Winter

Erstklassige Lebensqualität

Skifahren, Snowboarden, Schlitteln...

Freunde treffen



© GRF-Marco Hartmann





Leben in Bergün -
Wandern, Biken, Golfen, Kle...
Home Office
Natur Pur – Parc Ela